

FREEZE DRYING INNOVATION: LAB SCALE SOLUTIONS

Freeze Drying of Microspheres
by Spray Freezing and Dynamic Bulk Freeze Drying



MERIDION

TECHNOLOGIES

SprayCon LAB

Frozen Microspheres Generation in Lab Scale

Main Features

- Generation of frozen microspheres from ca. 300 μm up to ca. 600 μm (with elongated process chamber up to ca. 900 μm), including
 - High precision prilling nozzle
 - Insulated process chamber with product collection cone for droplet freezing
 - Lower compartment (cooled) with removable product container
 - Peristaltic pump for substrate feeding
- Throughput ca. 15 – 25 g/min (pellets size dependant)
- Cooling of process chamber by GN_2 / LN_2 (double wall)
- Measurement of process chamber temperatures
- Fully SCADA based control system with 15,6" HMI touchscreen

Options

- Elongation of process chamber (for larger particle generation > 600 μm)
- CiP nozzles & piping for automated & contained cleaning
- Droplet counting by light beam measurement
- Inertization of process chamber (GN_2)
- Contained product handling
- SiP

Technical Data

- Dimensions (W x L x H, in mm, ca.): 1,030 x 1,486 x 2,817 (height optionally up to 4,200; see last page for details). Control cabinet: separate
- Weight: ca. 1,100 – 1,300 kg
- LN_2 consumption: ca. 35 – 55 l/h
- Compressed air consumption: ca. 25 – 45 m^3/h
- 240 V AC, 50 Hz or 110 V AC, 60 Hz, max. ca. 3 kW

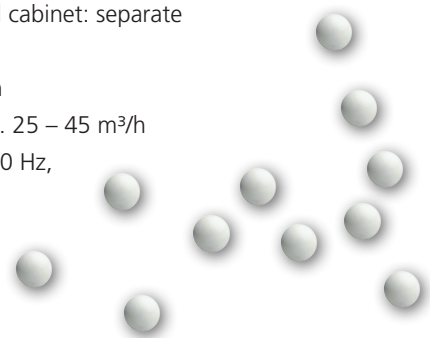

The control cabinet can be freely positioned, adapting to your needs

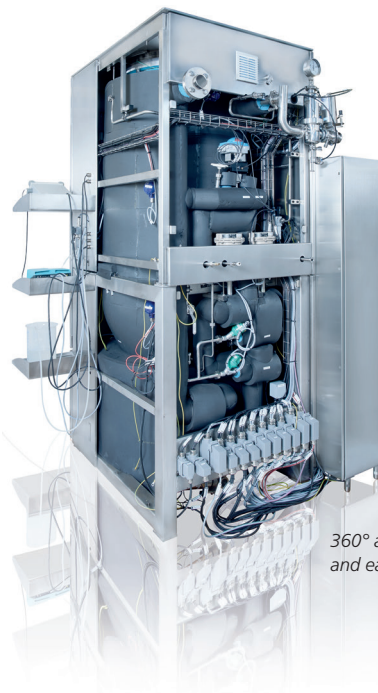

360° access for quick and easy maintenance

Cooled lower compartment for product container changing



Pivoting glass top lid for nozzle handling and process chamber inspection

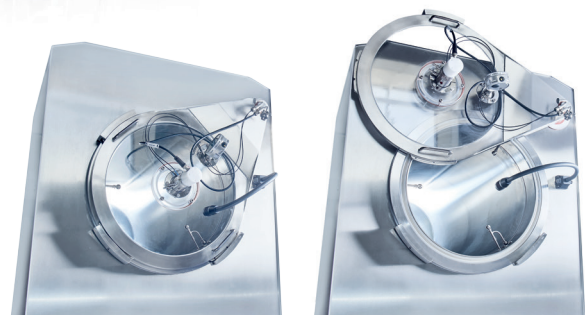

LyoMotion LAB

Dynamic Bulk Freeze Drying in Lab Scale

Main Features

- Dynamic freeze drying of frozen bulkware (0.3 – 2 l frozen bulk volume)
- Contained unit with
 - Vacuum process chamber (cooled)
 - double wall rotating drum with drive, including
 - Silicone oil drum cooling & heating (-50°C ... + 50 °C)
 - Chiller unit (2 stage), water cooled
 - Condenser (- 70°C)
 - Vacuum pump (for process pressure down to > 10 µbar)
 - IR radiator, fully covered and cooled
 - Closed internal discharging
 - Fully SCADA based control system with 15,6" HMI touchscreen
 - Integrated control cabinet

Options

- CiP nozzles & piping for automated & contained cleaning
- Inertization of process chamber (GN₂)
- Automated in-process-sampling out of vacuum
- Contained product handling
- SiP

Technical Data

- Dimensions (W x L x H, in mm, ca.): 850 x 2,189 x 1,999 (see last page for details)
- Weight: ca. 1.000 kg
- Compressed air consumption: ca. 20 – 25 m³/h
- Cooling water consumption: ca. 5 l/min during process, ca. 20 l/min during cooling down
- 400 V AC, 50 Hz or 480 V AC, 60 Hz max. ca. 5,5 kW

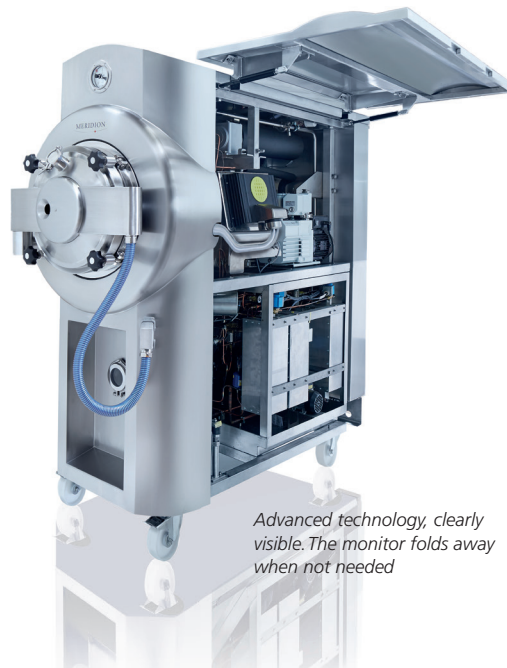

MERIDION

TECHNOLOGIES

MERIDION Technologies: Lab, Pilot and Production Scale

MERIDION is fully dedicated to the application of the innovative Spray Freeze Drying technology for the generation of lyophilized spheres, also for sterile applications. Product innovation (such as e.g. reconstitution time reduction or high protein concentrations) and significant strategic advantages in the generation of lyophilized bulkware by increasing manufacturing and supply chain flexibility are strong drivers in the utilization of the technology.

Located in south-western Germany, close to Basel (CH), MERIDION offers application lab facilities for process and/or product development and/or process verification (up to 20 kg pilot scale) and provides projects realization on all required scales, covering engineering, project management, equipment design, manufacturing and installation as well as start-up and after-sales-service.

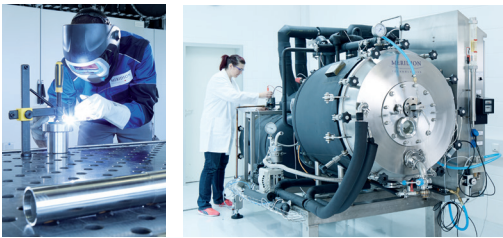

Integrated expertise – that's MERIDION!



Fully contained production scale pharma process line with spray freeze chamber and dynamic bulk freeze dryer

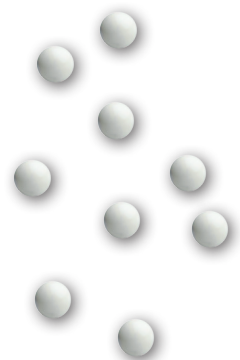

Dimensions SprayCon LAB

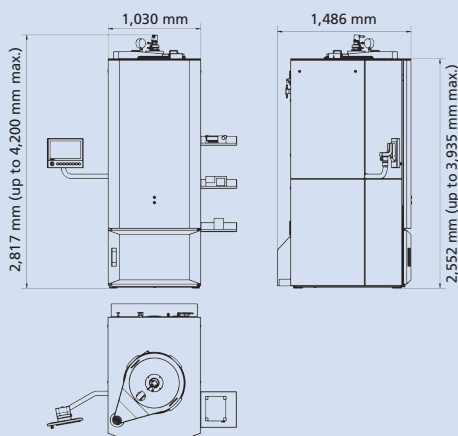

Dimensions LyoMotion LAB

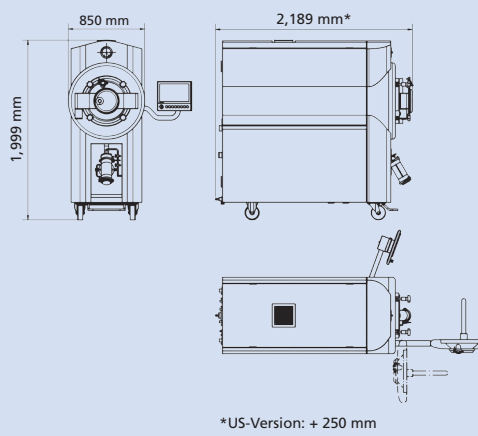

MERIDION Technologies GmbH
 Mauchener Str. 14
 D-79379 Müllheim/Germany
 Phone + 49 (0) 76 31 / 93 63 8 - 0
 Fax + 49 (0) 76 31 / 93 63 8 - 10
 info@meridion.de
www.meridion.de

